

720017

VHF/UHF Communications Antenna

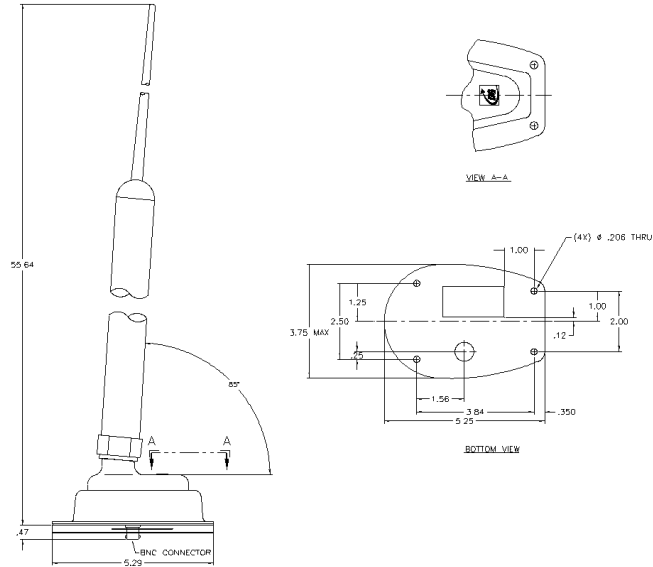

Excellence in Aerospace since 1943



Specifications

Electrical

Frequency	30-88 MHz 108-174 MHz 225-400 MHz
VSWR	2.5:1 at 30-88 MHz 2.5:1 at 108-174 MHz 2.0:1 at 225-400 MHz
Polarization	Vertical
Radiation Pattern	Omnidirectional
Impedance	50 ohms
Power	VHF: 50 Watts UHF: 100 Watts

Mechanical

Weight	1.8 lbs. max. (0.82 kg)
Height	56 in (1422 mm)
Material	Fiberglass and Aluminum
Finish	White Polyurethane
Connector	BNC

Environmental

Speed Rating	250 Knots
--------------	-----------

Federal Specifications

Approvals	None
-----------	------

720017 VHF/UHF Communications Antenna

The 720017 is a VHF/UHF high-gain, whip-style antenna.

Applications

Antenna is designed for installation on helicopters and utilized on fixed-wing aircraft flying at 250 knots or less.