

# UF10-825

## UHF Antenna

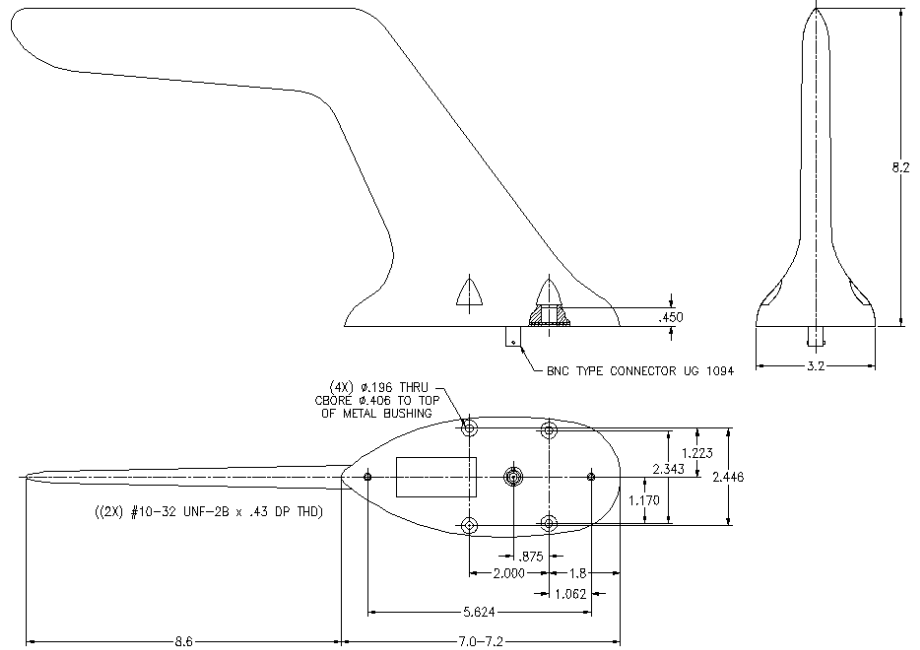

### Specifications

#### Electrical

Frequency	225-512 MHz
VSWR	2.0:1
Polarization	Vertical
Radiation Pattern	Omnidirectional
Impedance	50 Ohms
Power	100 Watts

#### Mechanical

Weight	1.2 lbs max (0.54 kg)
Height	8.2 in (208.3mm)
Material	Fiberglass
Color	Flat Black
Connector	BNC

#### Environmental

Speed Rating	600 knots
--------------	-----------

#### Approvals

MIL-STD-810C

### UF10-825 Antenna

The UF10-825 is a UHF communications antenna that offers coverage in the 225 to 512 MHz frequency band. The antenna has the same form and footprint as DG PN VFS10-90-( ) antenna. It is qualified to MIL-STD-810C.